

Data Sheet GU-LCT-IND-01

Part No.: AC-10199-001_C

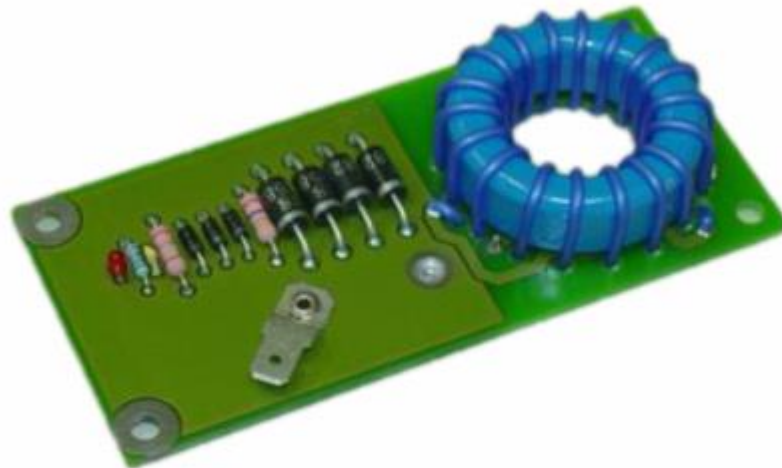

Inductive Coupling for GU-LCT-RY-V1-xx

Features

- For Series Connected Thyristors
- For Simultaneous Triggering
- Compact Design

Rev.	Remarks / changes	created		checked		released	
01	Initial, created from 5SYA1710-01	FF	14.08.12	AST	14.8.12	FF	15.8.12
02	Added gate wave form	AST	10.03.13	FF	12.03.13	AST	12.03.13
03	Changed header	AST	01.09.14	FF	01.09.14	AST	01.09.14

Table of Contents

1. Introduction	3
1.1. Description	3
1.2. Electrical interfaces	3
1.3. Environmental conditions	3
2. Connectors and indicator	3
2.1. Connectors	3
2.2. Indicator	3
3. Function	4
3.1. Gate current	4
3.2. Block diagram	4
4. Mechanical.....	5
4.1. Parameters	5
4.2. Mechanical Drawing.....	5
4.3. Labels.....	6
4.3.1. Front side	6
4.3.2. Rear side	6
4.3.3. Bottom side	6
4.3.4. Top side.....	6
5. Order code	6

1. Introduction

1.1. Description

The Inductive Coupling AC-10199-001 is to generate a trigger gate pulse for electrical triggered thyristors of any voltage class. To guarantee the isolation between the levels of series connected thyristors the inductive coupling circuits are used in combination with the trigger GU-LCT-RY-I1-xx and a closed loop high voltage cable through the input transformers. See also Order code.

1.2. Electrical interfaces

Parameter	Symbol	Condition	Min	Typ	Max	Unit
Trigger repetition rate	f	-			60	Hz
Gate trigger pulse	I _{GM}	Depends on count of series connected inductive couplings and GU-LCT. *	7	8	16	A

* Can be adjusted by factory.

1.3. Environmental conditions

Parameter	Symbol	Condition	Min	Typ	Max	Unit
Ambient temperature	T _{amb}	-	-40	-	+85	°C
Storage temperature	T _{store}	-	-40	-	+85	°C
Humidity	Hum	Non condensing	-	-	95	% RH
Operating altitude	Alt	-			3000	m

2. Connectors and indicator

2.1. Connectors

Parameter	Symbol	Description
Gate contact	G	-
Cathode contact	C	-

2.2. Indicator

The red LED indicates a broken Gate line or a defective Thyristor.



Make sure that the device work correctly before using in a critical application.

3. Function

3.1. Gate current

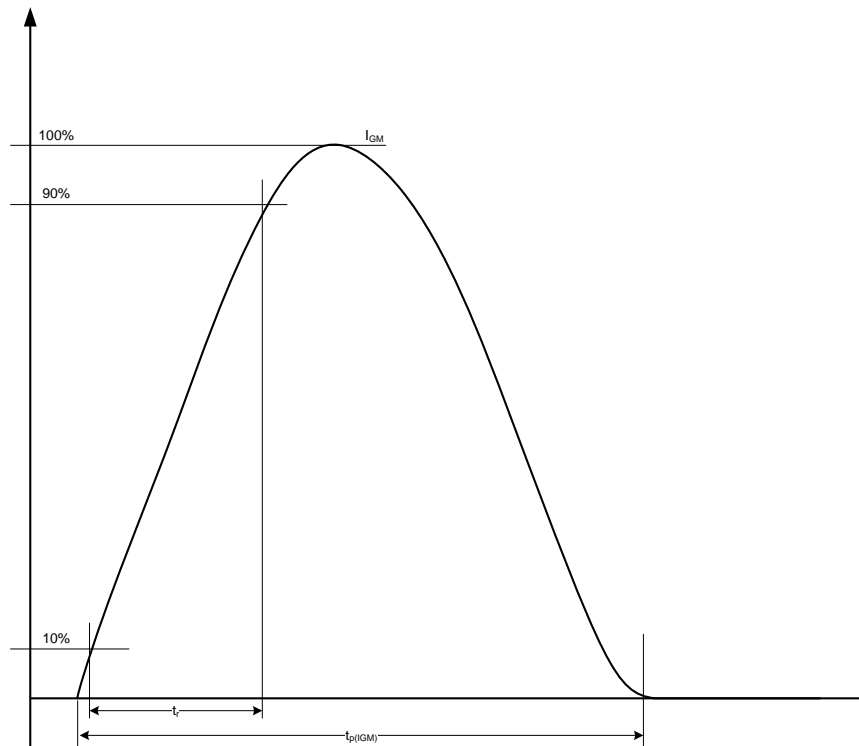

Parameter	Symbol	Condition	Min	Typ	Max	Unit
Rise time	t_R	10 – 90%	-	-	1	μs
Pulse time	t_P		5	-	20	μs
Gate Current	I_{GM}		7	-	16	A *

* Depends on count of series connected inductive couplings and GU-LCT and application. Can be adjusted by factory for customer needs.

3.2. Block diagram

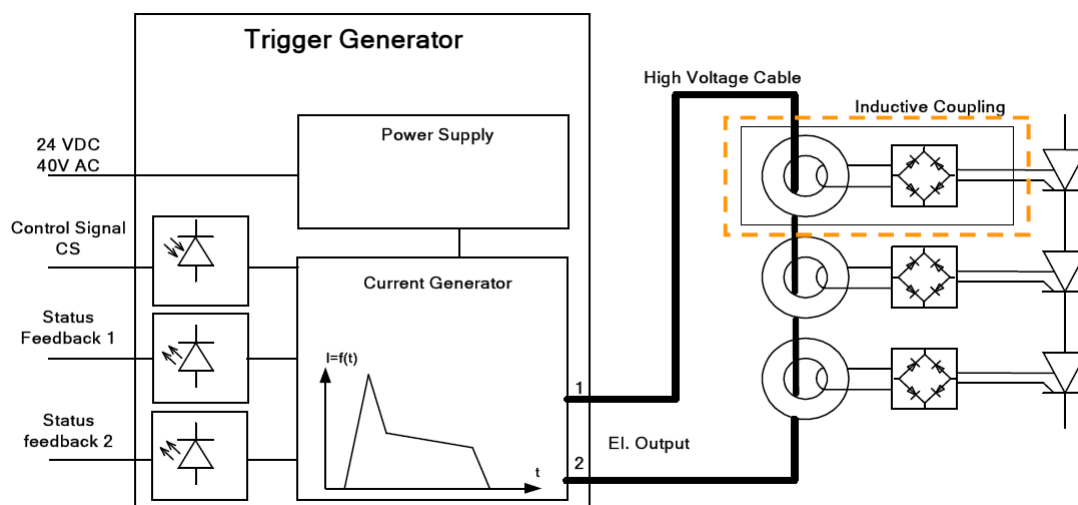

Trigger generator and HV cable do not belong to scope of supply. To be ordered separately.

Astrol Electronic AG reserves the right to change specifications without notice

4. Mechanical

4.1. Parameters

Parameter	Symbol	Condition	Min	Typ	Max	Unit
Weight	M	-		0.2		kg
Dimensions	WxDxH	-		(115 x 53 x 18)		mm

4.2. Mechanical Drawing

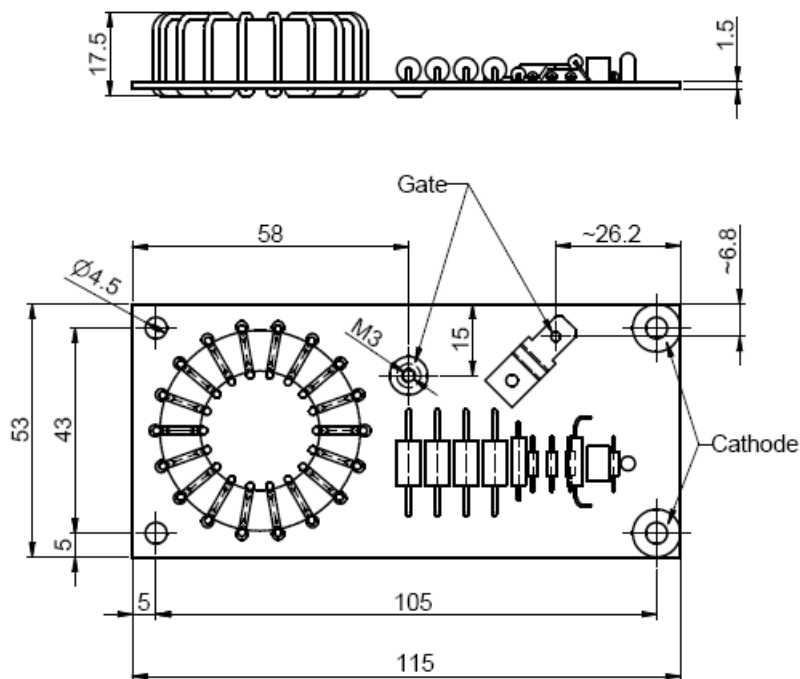

4.3. Labels

4.3.1. Front side

- Nothing

4.3.2. Rear side

- Nothing

4.3.3. Bottom side

- Type label with serial number

4.3.4. Top side

- Nothing

5. Order code

AC-10199-001_C

GU-LCT-IND-01 (THT version)

Astrol Electronic AG
Ahornweg 14
CH-5504 Othmarsingen
Switzerland

Phone: +41 (0) 56 485 60 20

Fax: +41 (0) 56 485 62 42

e-mail: info@astrol.ch

web: www.astrol.ch

Astrol Electronic AG reserves the right to change specifications without notice